

Astra Tech Implant System®

Manual and product catalog

## Guided surgery

Computer guided implant treatment with  
the Astra Tech Implant System® EV



## Simplicity without compromise

The design philosophy of the Astra Tech Implant System EV is based on the natural dentition utilizing a site-specific, crown-down approach supported by an intuitive surgical protocol and a simple prosthetic workflow, for increased confidence and satisfaction for all members of the treatment team.

- Versatile implant designs, including straight, conical, sloped, short, narrow and wide, using only one surgical tray
- Flexible drilling protocol allows for preferred primary stability
- Restorative components including round and triangular options supporting soft tissue sculpturing
- Unique interface with one-position-only placement for:
  - Atlantis patient-specific abutments
  - Self-guiding impression components that require only one hand for precise seating

The foundation of this evolutionary step remains the unique Astra Tech Implant System BioManagement Complex, well-documented for its long-term marginal bone maintenance and esthetic results.

# Astra Tech Implant System®

## CONTENTS

### Introduction

Drilling protocol .....	4
Implant assortment .....	4
OsseoSpeed® Profile EV .....	5
Tray concept .....	6
Guided surgery: tray and drilling protocol guide - Proline .....	8
Simplant® SAFE Guide .....	9

### Implant site preparation

Surgical components and instruments overview .....	10
Immediate Smile® for Astra Tech Implant System® EV .....	13
Fixation System .....	15
Drilling protocol for OsseoSpeed® EV - straight .....	16
Drilling protocol for OsseoSpeed® EV - conical .....	17
Osteotomy preparation alternatives .....	18
Step-by-step implant placement: OsseoSpeed® EV .....	19
Step-by-step: Immediate temporary restoration .....	24
Guided surgery - Design features .....	26

### Product catalog

One surgical tray - two overlay options .....	29
Cortical Preparation .....	32
Alternative Spongious Preparation .....	33
Fixation System .....	35

This manual is designed for use by clinicians who have undergone appropriate education and training in surgical and prosthetic implant treatment. Staying current on the latest trends and treatment techniques in implant dentistry through continued education is the responsibility of the clinician.

This manual only addresses the additional information needed to work with guided surgery using Astra Tech Implant System EV. For all other instructions and/or a full description of the Astra Tech Implant System EV implant placement, restorative procedures and all instruments and components needed, please refer to the Surgical manual, OsseoSpeed Profile EV manual, Cement-, Screw-, and Attachment-retained restorations manuals and the Product Catalog Astra Tech Implant System EV.

All products may not be regulatory cleared/released/licensed in all markets. Please contact your local Dentsply Sirona sales office for current product assortment and availability.

To improve readability for our customers, Dentsply Sirona does not use ® or ™ in body copy. However, Dentsply Sirona does not waive any right to the trademark and nothing herein shall be interpreted to the contrary.

Product illustrations are not to scale.



## Drilling protocol

The density and orientation of trabeculae in spongy bone differ from patient to patient and from location to location. These variations can create differences in perceived resistance when preparing the implant site and installing the implant. The marginal cortical bone, however, is most often homogeneous in quality but may vary in thickness from case to case, which requires a mandatory adaptive preparation method.

A unique drilling protocol has been developed to allow for preferred primary implant stability. The strategy with the drilling protocol is to provide apical bone support to the implant when indicated, but to relieve the apex from bone contact when this support is not indicated.

The stepped osteotomy, providing apical bone support for the implant, is indicated in soft bone situations. In other situations, the apical portion of the osteotomy can be widened using the V- or X-drill. The X-drill also widens the body portion of the osteotomy and is indicated in more dense bone situations, e.g. in the lower jaw.

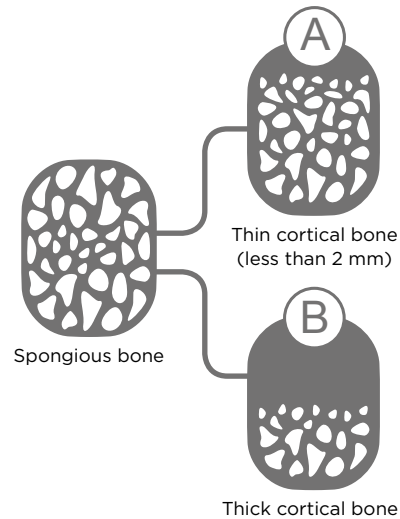

## Implant assortment for guided surgery

OsseoSpeed EV implants are available in a versatile range of shapes, diameters and lengths for all indications, including situations with limited space and/or bone quantity.

Specific colors have been assigned to the different implant-abutment connection sizes, which are consistently used throughout the system and identified by symbols and colors.

**Note:** OsseoSpeed Profile EV implants and components are additionally marked with a “P”.

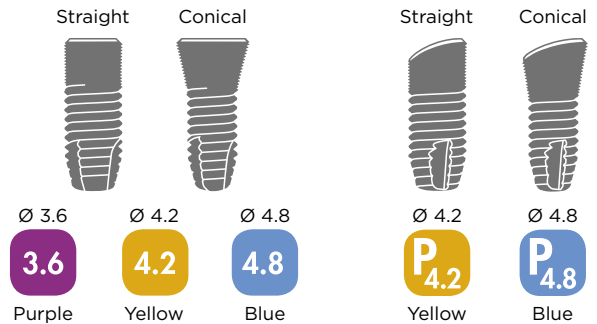

The guided surgery assortment of Astra Tech Implant System EV supports the following implants:

- OsseoSpeed EV straight implants
  - diameters 3.6 S, 4.2 S and 4.8 S
  - lengths 6 mm - 15 mm
- OsseoSpeed EV conical implants
  - diameters 4.2 C and 4.8 C
  - lengths 8 mm - 15 mm
- OsseoSpeed Profile EV straight implants
  - diameters 4.2 PS and 4.8 PS
  - lengths 8 mm - 15 mm
- OsseoSpeed Profile EV conical implants
  - diameters 4.2 PC and 4.8 PC
  - lengths 8 mm - 15 mm

OsseoSpeed® EV									
	Straight			Conical		Profile Straight		Profile Conical	
Ø	3.6	4.2	4.8	4.2	4.8	P <sub>4.2</sub>	P <sub>4.8</sub>	P <sub>4.2</sub>	P <sub>4.8</sub>
	3.6 S	4.2 S	4.8 S	4.2 C	4.8 C	4.2 PS	4.8 PS	4.2 PC	4.8 PC
Length									
6 mm	+	+	+						
8 mm	+	+	+	+	+	+	+	+	+
9 mm	+	+	+	+	+	+	+	+	+
11 mm	+	+	+	+	+	+	+	+	+
13 mm	+	+	+	+	+	+	+	+	+
15 mm	+	+	+	+	+	+	+	+	+



# OsseoSpeed® Profile EV

## Sloped alveolar ridge situations

A sloped alveolar ridge situation can often be expected in a fresh extraction site or after healing.

With a regular implant design, when the implant is placed level with the buccal bone margin, the lingual/palatal and proximal bone coronal to the implant is left without biomechanical support. This may lead to remodeling and loss of bone and soft tissue height, resulting in less than optimal esthetics.

An implant placed level with the palatal/lingual bone margin leaves the implant protruding out of the bone on the buccal side. This can result in discoloration of the buccal soft tissue margin or, in a worst-case scenario, a soft tissue dehiscence, causing compromised esthetics.

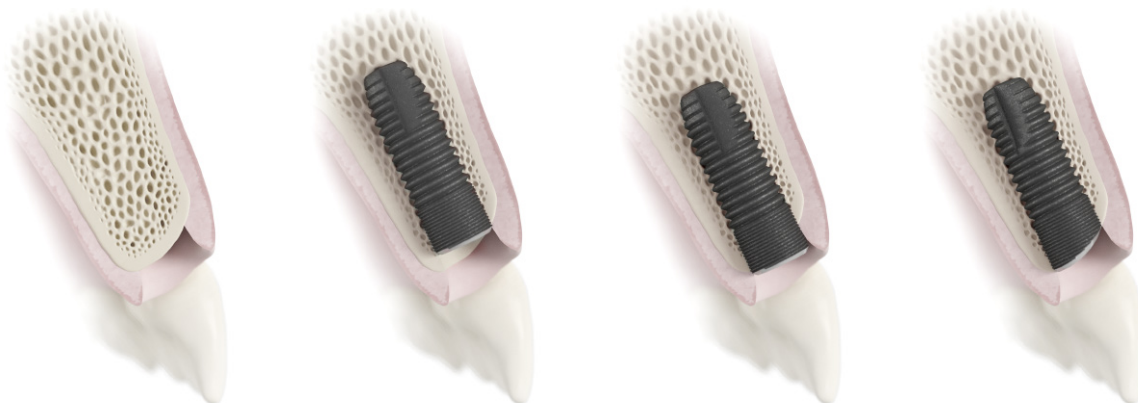

## OsseoSpeed® Profile EV – anatomically designed for sloped ridges

In a sloped ridge situation, an implant that is designed to be in harmony with the ridge profile is the optimal solution for preserving the marginal bone and supporting the soft tissue all around the implant. The OsseoSpeed Profile EV is designed especially for sloped ridge situations.

As a part of the Astra Tech Implant System EV, OsseoSpeed Profile EV implants are supported by the Astra Tech Implant System BioManagement Complex, well documented for its long-term marginal bone maintenance and esthetic results.

## Implant slope variance

As a result of the sloped neck design, the height variance at the top of the implant is 1.3–1.7 mm depending on the implant diameter and design.

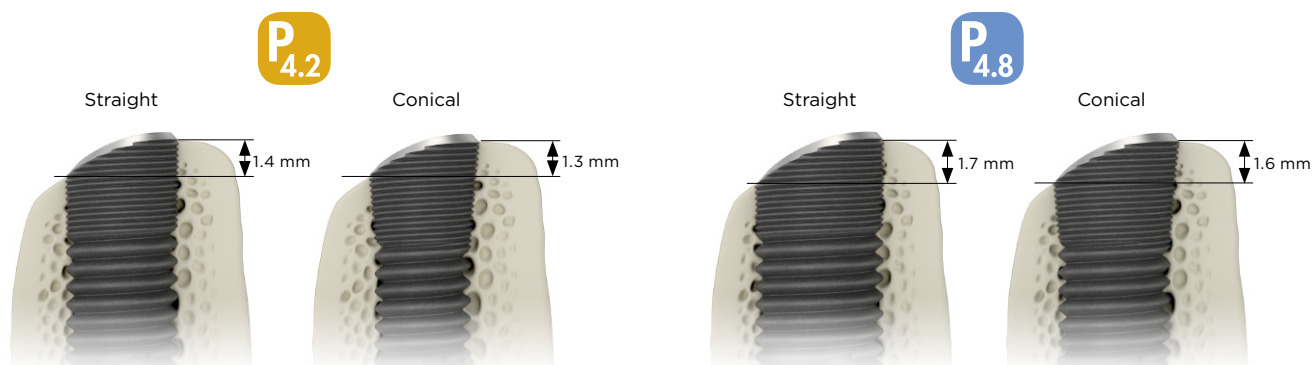

For further information about OsseoSpeed EV Profile, see the Astra Tech Implant System Profile EV manual.

# Tray concept

The tray layout and components are organized to support the user throughout the entire guided surgery procedure. The tray design eliminates the need for rubber grommets for holding drills and instruments, which simplifies the cleaning process.

The layout is printed on the overlay, which is snapped onto the tray base. This solution offers the possibility of adapting the tray's contents according to individual preferences.



## Streamline Base Kit

The Streamline Overlay is designed for straight implants with diameters of 3.6 mm, 4.2 mm, and 4.8 mm in lengths of 6 mm to 15 mm.

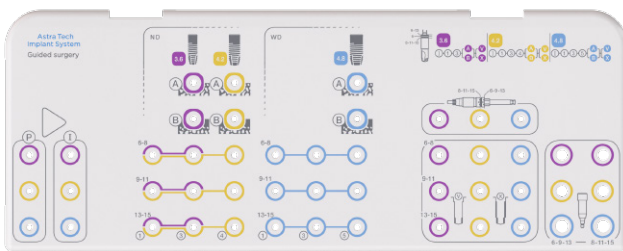

Straight



Ø 3.6	Ø 4.2	Ø 4.8
<b>3.6</b>	<b>4.2</b>	<b>4.8</b>
Purple	Yellow	Blue

## Proline Base Kit

The Proline Overlay supports the full assortment of OsseoSpeed EV Straight, Conical and Profile implants.

Straight implants are available in diameters of 3.6 mm, 4.2 mm and 4.8 mm in lengths of 6 mm to 15 mm.

Conical and Profile EV implants are available in diameters of 4.2 mm and 4.8 mm in lengths of 8 mm to 15 mm.

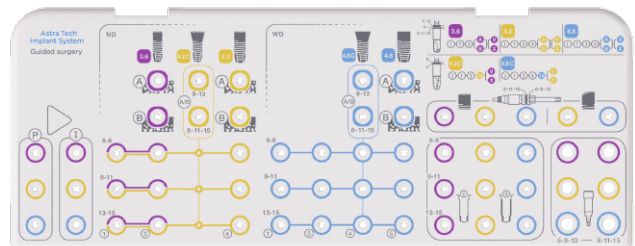

Straight

Conical

Straight

Conical



Ø 3.6	Ø 4.2	Ø 4.8	Ø 4.2	Ø 4.8
<b>3.6</b>	<b>4.2</b>	<b>4.8</b>	<b>P 4.2</b>	<b>P 4.8</b>
Purple	Yellow	Blue	Yellow	Blue

## Tray logics

The color-coded large tray has a drill marking system for ease of use and effective handling throughout the procedure, based on the following principles:

- Drills for the spongy bone preparation are color-coded white and marked with drill numbers 1-6 on the drill shaft.
- Drills for the mandatory cortical bone preparation are color-coded according to the implant and marked with either an A or B for straight implants or A/B for conical implants.
- Drills for relieving the apical bone support and widening of the osteotomy are color-coded according to the implant and marked with V or X.
- In addition to the diameter, all drill shafts are marked with a number or letter for easy identification and reference.

Please place the instruments and components in the tray according to the Tray-Guide overview on page 8.

## Delivery mode

To treat a guided surgery clinical case with the Astra Tech Implant System EV, a Base Kit and all necessary components have to be ordered. By using Simplant software or mySimplant planning service, the case-specific drills will be delivered with the Simplant SAFE Guide.

Two types of Base Kits can be ordered:  
The Streamline Base Kit and the Proline Base Kit

The Streamline Base Kit consists of:

- Tray with Streamline Overlay
- Mandatory Cortical Drills: A-Drill, B-Drill
- Initial Drills
- Implant Drivers for OsseoSpeed EV
- Stabilization Abutments
- Torque Wrench EV and Surgical Driver Handle

The Proline Base Kit consists of:

- Tray with Proline Overlay
- Mandatory Cortical Drills: A-Drill, B-Drill and A/B-Drills
- Initial Drills
- All Implant Drivers incl. OsseoSpeed Profile EV
- Stabilization Abutments
- Torque Wrench EV and Surgical Driver Handle

By ordering a Simplant SAFE Guide, the case-specific selection of all necessary drills and instruments according to the planned OsseoSpeed EV implant types will be added to your order. If using planning software other than Simplant, the necessary components have to be ordered separately.

Should a case-specific drill already be present, additional components can be excluded from the order. In this case, only the single-use drill sleeves will be delivered.

The case-specific drills together with either the Streamline or the Proline Base Kit support the complete surgical treatment protocol specified for Astra Tech Implant System EV.

## Drill systematic

Spongy bone preparation



Cortical bone preparation  
- straight implants



Cortical bone preparation  
- conical implants



Spongy bone preparation



# Guided surgery: tray and drilling protocol guide - Proline

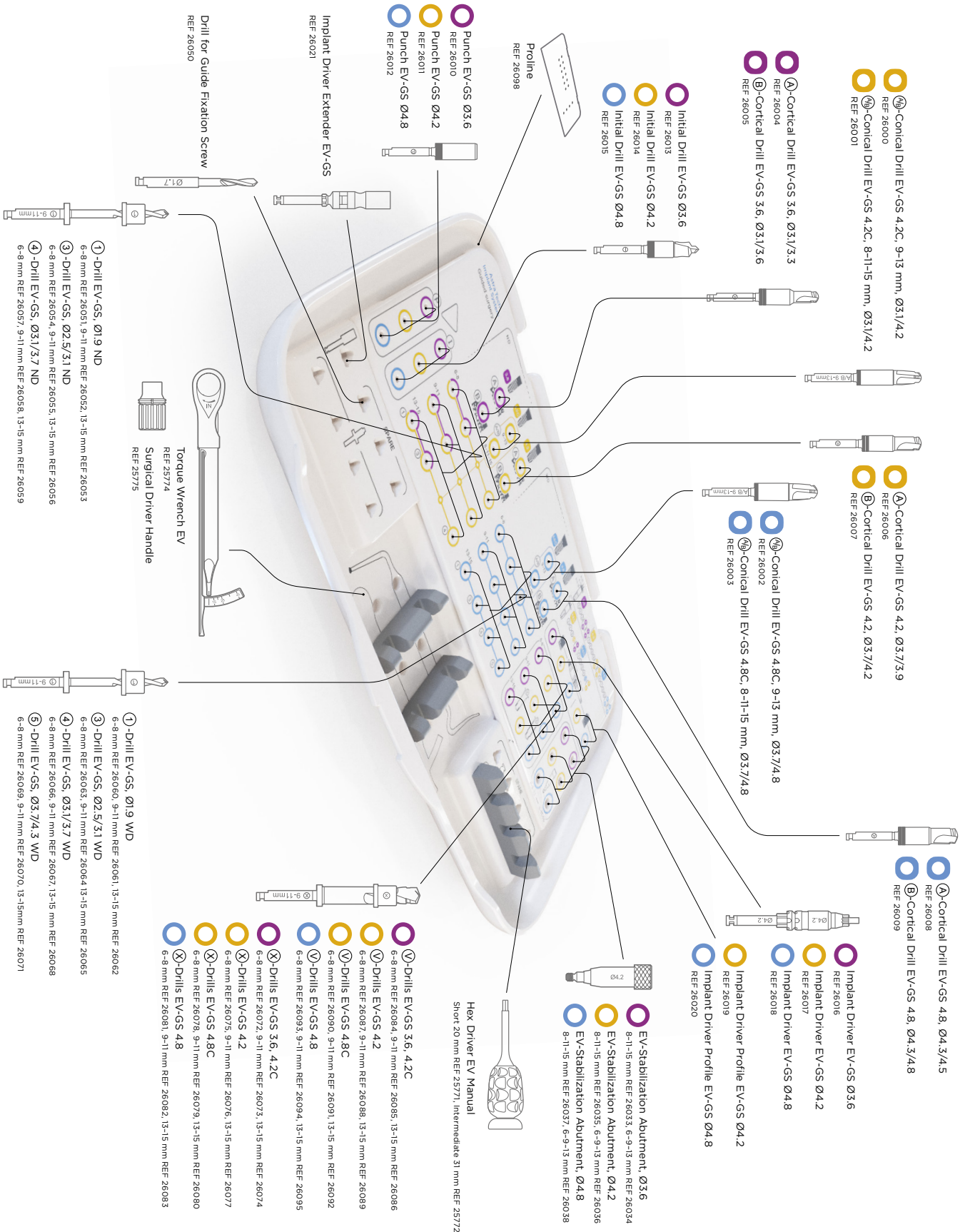

# Simplant SAFE Guide

The manual describes the procedure when using a Simplant SAFE Guide.

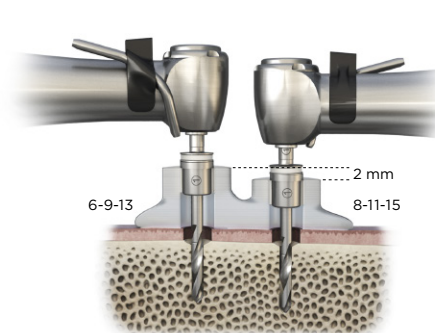
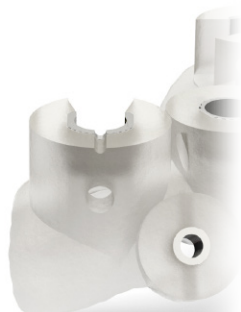

## Guide types

By using Simplant, three types of SAFE Guide are available for computer-guided surgery with Astra Tech Implant System EV:

### Bone-supported guide

for optimal, stable template seating for edentulous patients and ideal in combination with augmentation.

### Mucosa-supported guide

for minimally invasive procedures (e.g. flapless surgery) for edentulous patients.

**Note:** Infiltration may cause minor changes to the mucosa topography and less stable fit of the mucosa-supported guide.

### Tooth-supported guide

for partially edentulous patients. A plaster cast or the scan of the plaster model (Optical Scan module) is needed to enable optimal fit of the guide.

**Note:** Immediately before use of the guide on the patient, follow the reprocessing instructions of the manufacturer of the guide or, if applicable, of the guide material. The guide has to be checked for an exact fit. To avoid injuries to the soft tissue, ensure moderate application of force at all times.

## Lateral access

A Simplant SAFE Guide can be ordered with or without a lateral drill guide access.

The lateral access provides additional convenience by reducing the insertion height of the drill by at least 4 mm, up to 10 mm, depending on the implant position and the thickness of the mucosa. This facilitates guided surgery in cases with limited space.

On the following pages, the computer-guided implant treatment with the Astra Tech Implant System EV is described using the Simplant SAFE Guide as a representative model. However, if not specifically mentioned, the descriptions are generally applicable for the use of a compatible (for US: FDA cleared) software-designed drill guide. The term “guide sleeve” refers to the Simplant SAFE Guide inserts and also to the guiding section of other compatible guides.

## Dynamic guide sleeve position

The positions of the guide sleeves in the SAFE Guide are adjusted to the planned implant length. One drill length can accommodate different osteotomy depths. The guide sleeve position will be added by the planning software according to the planned implant length. Manual adjustments are not possible.



The guided instruments are at least 11 mm longer than the non-guided assortment.

Consider during planning in the software that the drill tip can be up to 1 mm longer than the implant.

See chapter “Guided surgery – Design features” on page 26/27.

# Surgical components and instruments overview

All drills are delivered sterile and are reusable for approximately 10 cases. The Punch and Sleeves are delivered sterile but are single-use.

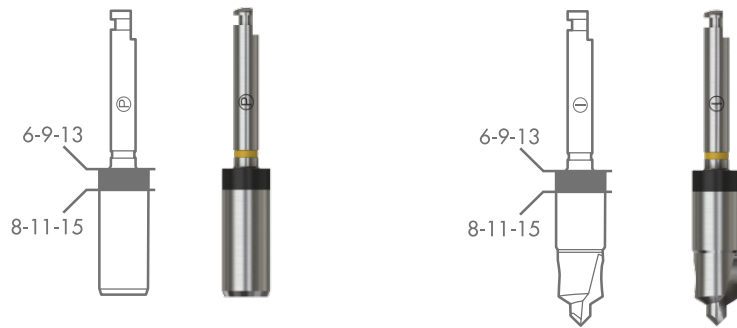

## Punch for soft tissue preparation

The punch, marked with a (P), is used to make a minimally invasive circular incision in the soft tissue. It is a single-use punch guided directly by the guide sleeve.

- Laser marking corresponds to the implant length and diameter
- Color: corresponds to the implant
- Sterile and single use only
- Can be ordered together with Simplant SAFE Guide

## Initial Drill

After using the optional punch, the mandatory Initial Drill is used to remove the soft and hard tissue and to prepare the shape of the bone for the first full-length drill. The Initial Drill is marked with an (I) and is guided directly by the guide sleeve.

- Laser marking corresponds to the implant length and diameter
- Color: corresponds to the implant
- Sterile and multiple-use, approximately 10 cases



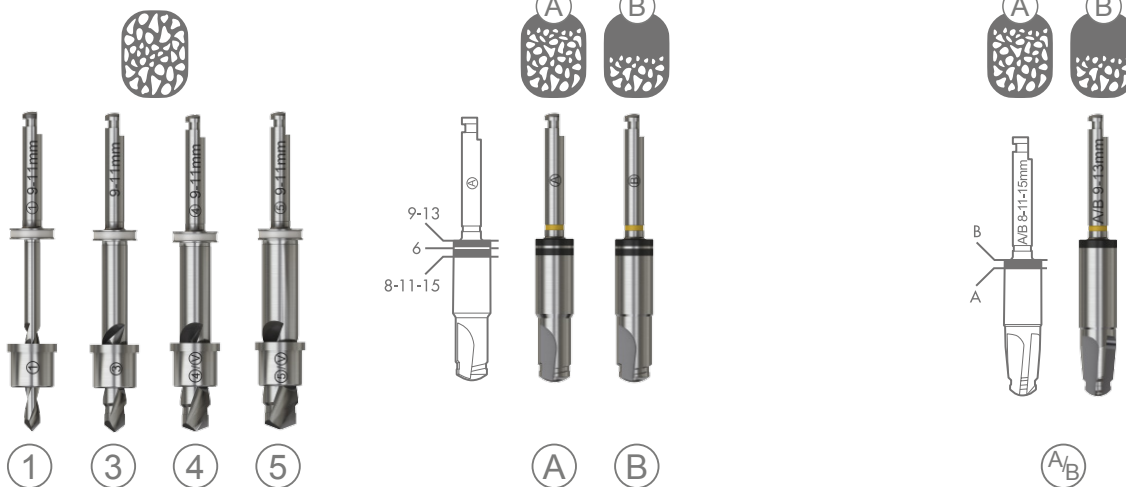

### Spongy bone preparation

Full length drills (Sleeve-on-Drill system) with mechanical depth stop are used for the osteotomy preparation. The osteotomy design ensures proper preparation of the bone for implant placement, while achieving the preferred level of primary stability.

- Color: white
- Laser marking: drill diameter and number, implant length and diameter
- Drill lengths available according to the implant length:  
6-8 mm, 9-11 mm, 13-15 mm
- Drill: sterile and multiple-use, approximately 10 cases
- Drill Sleeve: sterile and single-use only
- Can be ordered together with Simplant SAFE Guide

### Cortical bone preparation – straight implants

The (A) or (B) Cortical Drill is used for the mandatory preparation of the cortical layer to reduce pressure in the bone around the implant neck. The Cortical Drills are guided directly by the guide sleeve.

- Color: corresponds to the implant
- Markings: diameter and drill letter
- A - thin cortical bone < 2 mm
- B - thick cortical bone ≥ 2 mm
- Sterile and multiple-use, approximately 10 cases

**Note:** There is a separate depth marking for the 6 mm sleeve.

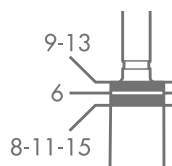

### Cortical bone preparation – conical implants

Mandatory preparation of the cortical layer to reduce pressure in the bone around the implant neck.

The drill marked (A/B) is used to prepare the conical shape of the cavity.

The intended preparation depth (A) or (B) has to be chosen depending on the thickness of the cortical bone.

- (A) - thin cortical bone < 2mm,
- (B) - thick cortical bone ≥ 2mm

The Cortical Drills are guided directly by the guide sleeve.

- Color: corresponds to the implant
- Laser marking: drill letter, implant diameter and length
- Two lengths available:  
9-13 mm and 8-11-15 mm
- Sterile and multiple-use, approximately 10 cases

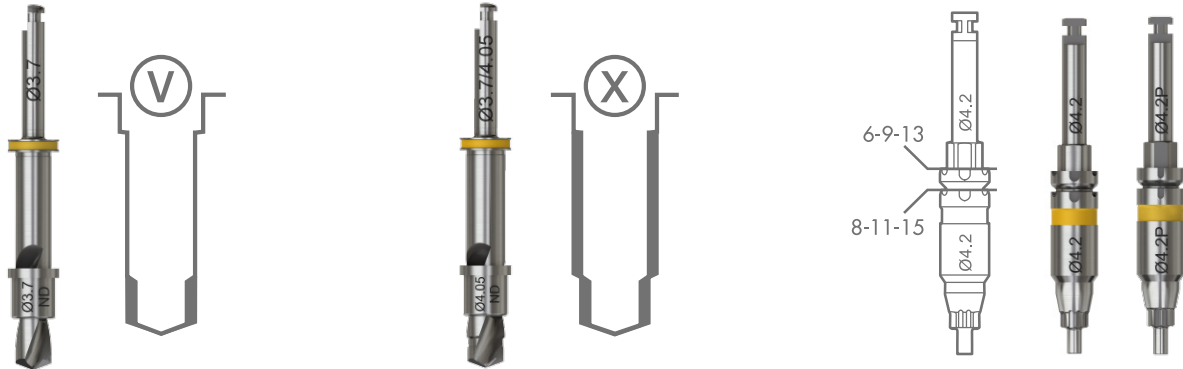

### Alternative spongy bone preparation

#### V-Drill EV-GS – extra apical preparation

Following opening of the marginal cortical layer with cortical drill (A), (B) or conical drill (A<sub>b</sub>), the (V) drill is used to relieve the apical bone support when this support is not indicated.

- Color: corresponds to the implant.  
**Note:** for conical implants, this color refers to the implant body diameter.
- Laser marking: drill diameter, implant length and (V)
- Drill lengths available according to implant length: 6–8 mm, 9–11 mm, 13–15 mm
- Drill: sterile and multiple-use, approximately 10 cases
- Sleeve: sterile and single-use only
- Can be ordered together with Siplant SAFE Guide

#### X-Drill EV-GS – extra body preparation

Following opening of the marginal cortical layer with cortical drill (B) or conical drill (A<sub>b</sub>), the (X) drill, in addition to relieving the apical bone support, is used to widen the body portion of the osteotomy in situations with more dense bone e.g. the lower jaw.

- Color: corresponds to the implant.  
**Note:** for conical implants, this color refers to the implant body diameter.
- Laser marking: drill diameter, implant length and (X)
- Drill lengths available according to the implant length: 6–8 mm, 9–11 mm, 13–15 mm
- Drill: sterile and multiple-use, approximately 10 cases
- Sleeve: sterile and single-use only
- Can be ordered together with Siplant SAFE Guide

#### Implant Driver EV-GS Implant Driver Profile EV-GS

Used for picking up and installing the implant through the sleeve of the guide in the prepared osteotomy. The Implant Driver EV-GS can only engage into a single position of the implant. For OsseoSpeed Profile EV, align the notch on the Implant Driver Profile EV with the most crestal point of the implant slope.

The two grooves on the shaft indicate the corresponding implant lengths 8-11-15 mm and 6-9-13 mm.

- Available for Straight and Conical or Profile EV, guided directly by the guide sleeve
- ISO Hex shaft
- Color: corresponds to the implant
- Grooves indicate the implant depth in relation to the guide sleeve.
- One of the six notches is for aligning to the single notch of the guide sleeve in the Siplant SAFE Guide for standard Abutments and OsseoSpeed EV Implants.
- The single long notch must align with the notch of the sleeve in the Siplant SAFE Guide for pre-surgically manufactured Atlantis patient-specific abutments or OsseoSpeed Profile EV Implants.

**Note:** In order to avoid tilting, there must not be any pressure on the drill guide. Hence, instead of a mechanical depth stop, the implant driver has two groove markings. This prevents stripping of the implant thread and damage to the implant site. The implant driver should preferably be used with a torque-controlled contra-angle handpiece or with the Torque Wrench EV and the Surgical Driver Handle EV.



# Immediate Smile® for Astra Tech Implant System® EV

The Immediate Smile solution featuring Atlantis Abutment offers guided surgery and guided soft tissue healing for immediate temporizations, already at time of tooth extraction. This solution consists of a Siplant SAFE Guide, an Atlantis Abutment and a temporary crown based on the Atlantis Abutment Core File and is currently indicated for single-tooth implant restorations. For more details see: *“Immediate Smile - featuring Atlantis Abutment, Clinical and laboratory procedures”*.



The implant must be installed to the planned height and index orientation for proper seating and positioning of the already manufactured Atlantis patient-specific abutment.

## Implant-abutment interface connection

The Astra Tech Implant System EV features a one-position-only placement of patient-specific Atlantis Abutments for restorative ease.

The Immediate Smile treatment concept is based on patient-specific Atlantis Abutments designed and manufactured prior to surgery.



OsseoSpeed EV



OsseoSpeed Profile EV

The notch in the sleeve of the Siplant SAFE Guide is oriented buccally for OsseoSpeed EV Implants and lingually for OsseoSpeed Profile EV.

By aligning the single long notch of the Implant Driver with the notch in the guide sleeve, the pre-manufactured, patient-specific Atlantis Abutment will be correctly indexed upon abutment connection.

**Note:** If you rotate the implant in the Siplant Software, an additional notch will be present around the sleeve in the guide. The single long notch in the Driver has to be aligned with this additional notch in the guide.

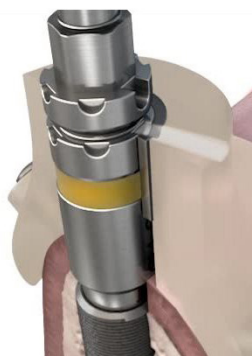

### Abutment placement option

#### One-position-only

Atlantis patient-specific abutments and all indexed components for OsseoSpeed Profile EV will seat in one position only.



#### Six positions

Indexed abutments will seat in six available positions.



#### Index free

Index-free abutments will be seated in any rotational position.



The single long notch that is to be used for implant indexing during Immediate Smile featuring Atlantis Abutment procedures is longer and deeper in comparison to the other notches.



Six Notches for OsseoSpeed EV straight and conical implants



Only one notch for OsseoSpeed Profile EV implants



### Sleeve-on-Drill™

The Sleeve-on-Drill guides the drill in the sleeve of the guide. The following steps describe the handling of the Sleeve-on-Drill concept.

- Push the drill sleeve manually over the drill tip, using anti-clockwise direction, until the sleeve snaps into the groove of the drill.
- Put the drill with the mounted drill sleeve into the sleeve of the guide.
- Start drilling with max. 1500 rpm.
- Prepare the osteotomy until the depth stop of the drill is reached.
- While rotating, pull the drill out of the osteotomy until the drill sleeve snaps into the groove of the drill again.
- Stop drilling!
- Finally remove the drill with the attached sleeve out of the guide sleeve.
- Laser markings: drill sleeve inner diameter, outer size ND=narrow diameter or WD=wide diameter and drill step and type
- Sterile and single-use only
- Can be ordered together with the Siplant SAFE Guide

### Implant Driver Extender EV-GS

The Extender EV-GS can be used for the drills and implant drivers in case of limited space between teeth. Align the flat shaft of the instrument with the dot marking on the Implant Driver Extender and snap into position.

### EV-PositioningAid EV-PositioningAid Profile

For pre-manufactured immediate prosthetic restorations used with the SAFE Guide.

- Available for Straight and Conical or Profile EV
- Precise transfer of the planned implant position to the master cast
- Color: corresponds to the implant
- Markings: implant type, diameter and length
- Two lengths available:  
6-9-13 mm and 8-11-15 mm
- Multiple-use

**Note:** Before using the PositioningAid, check for damage on the outside. If signs of wear are visible, replace it with a new one.

# Fixation System



## EV-Stabilization Abutment

The stabilization abutment secures the Guide against lateral and horizontal displacement and twisting when multiple implant sites are prepared.

At least one implant should be provided with a stabilization abutment.

The Abutment should be hand-tightened, especially when OsseoSpeed Profile EV Implants are used. For easier removal, use the Hex Screwdriver EV.

- Color: corresponds to the implant
- Markings: implant size and length
- Two lengths available:  
6-9-13 mm and 8-11-15 mm

## Guide Fixation Screw

It is recommended to secure the mucosa-supported guide with fixation screws. Place Guide Fixation Screws through the SAFE Guide to reduce lateral and horizontal movements. The screw position has to be planned with the Siplant Software and it is mandatory for the preparation with the Guide Fixation Screw.

- Precise implant placement by connecting mucosa-supported guides with the bone through the Guide Fixation Screw
- Sterile and single-use only
- Hex Driver EV is used

## Drill for Guide Fixation Screw

Directly guided Drill (Ø 1.7 mm) through the SAFE Guide, is used to prepare the Guide Fixation Screw.

- Sterile and multiple-use, approximately 10 cases

# Guided Surgery

Drilling protocol for OsseoSpeed® EV – straight



Drilling protocol for OsseoSpeed® Profile EV – straight

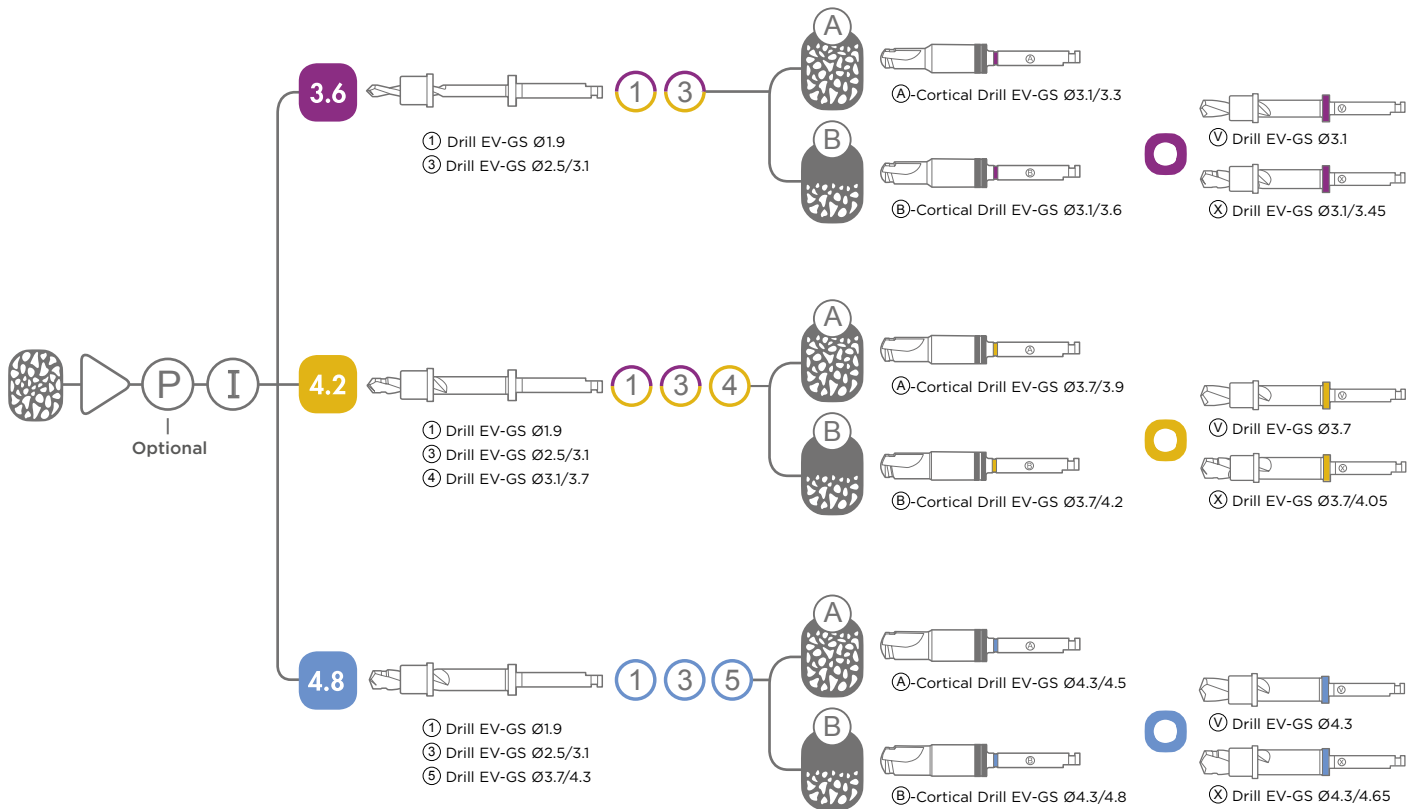

# Guided Surgery

## Drilling protocol for Osseospeed® EV - conical



## Drilling protocol for Osseospeed® Profile EV - conical



Conical implants are available for situations with limited bone volume where a diameter 3.6 or 4.2 mm implant body is the choice but where a larger prosthetic platform is preferred.



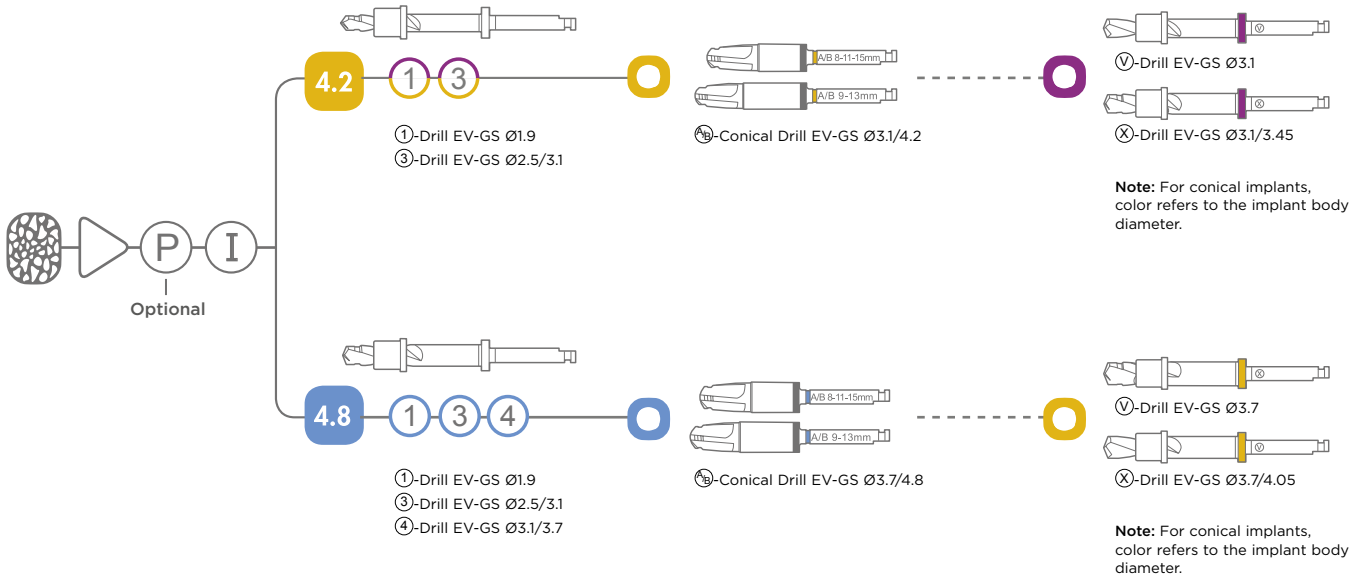



**Note:** If an additional spongy bone preparation with V or X drill is performed, use the color that refers to the implant body diameter.



# Osteotomy preparation

## Mandatory

## Alternative\*

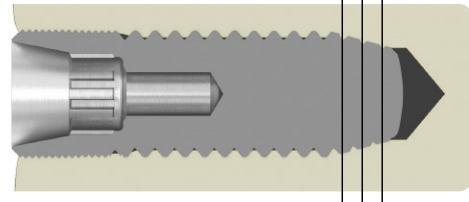
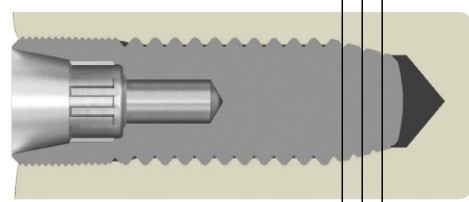
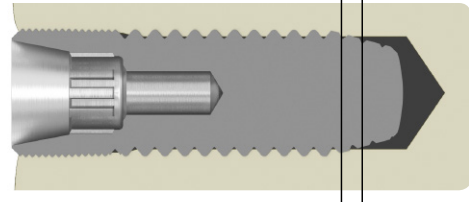
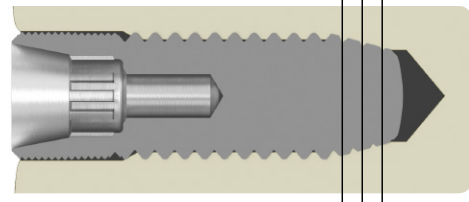
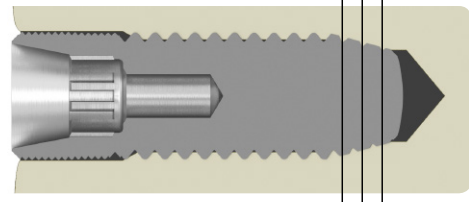
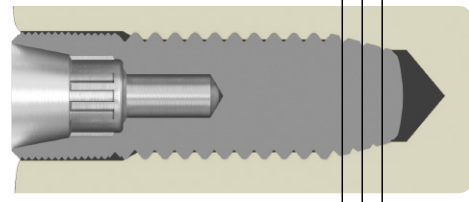
Spongy bone preparation	Cortical bone preparation	Spongy bone preparation
 Thin cortical bone	 Thin cortical bone	 Extra apical preparation (V)
 Thin cortical bone	 Thin cortical bone	 Extra body preparation (X)
 -0.5 -0.8 -0.4 0	 -0.3 -0.5 -0.8 -0.4 0	 -0.5 -0.3 0
 -0.0 -0.5 -0.8 -0.4 0	 -0.0 -0.5 -0.8 -0.4 0	 -0.0 -0.5 -0.8 -0.4 0

The spongy bone preparation results in an under-preparation compared to the implant diameter of 0.5 mm at the body portion. Corresponding under-preparation at the apex is from where the apex begins towards the tip of the implant, 0.8, 0.4 and 0 mm respectively.

After completion of the spongy bone preparation, mandatory use of cortical drill (A) or (B) will result in an under-preparation, at the margin, of 0.3 mm or 0 mm respectively compared to the marginal implant diameter.

The stepped osteotomy, which provides apical bone support, is indicated in soft bone situations. In other situations, the osteotomy can be widened using the (V) or the (X) drill.

(V) drill: for apical widening, use the (V) drill resulting in an apical under-preparation, from where the apex begins towards the tip of the implant, of 0.3 mm or 0 mm respectively at the apex portion.

(X) drill: for body and apical widening, use the (X) drill. This results in an under-preparation at the body portion of 0.15 mm. At the apical portion the under-preparation is 0.3 mm or 0 mm respectively from where the apex begins towards the tip of the implant.

**\*Note:** Not recommended in soft bone situations.

# Step-by-step implant placement: OsseoSpeed® EV

For preparation and installation of an OsseoSpeed EV implant, follow the steps below. A mucosa-supported guide is presented in the example below.

**Note:** All drilling, except for the Punch, should be performed at a maximum speed of 1500 rpm with profuse irrigation.  
All EV-GS instruments should be fully inserted into the guide sleeve of the Simplant SAFE Guide before drilling is started.

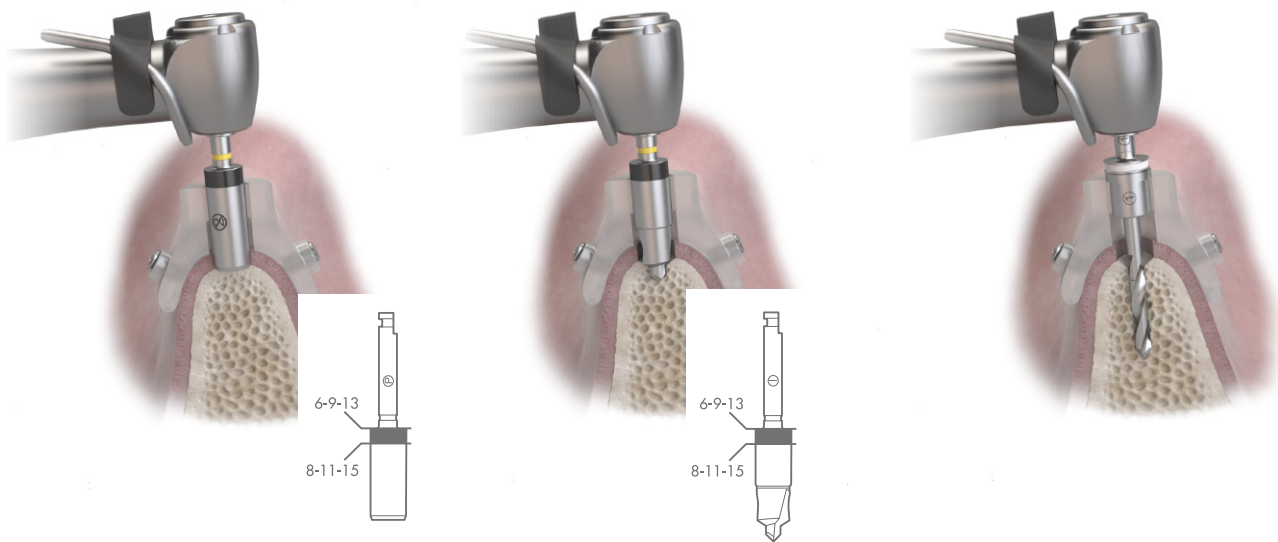

## Punch EV-GS

The directly guided single-patient Punch EV-GS is used for a minimally invasive circular incision for the planned implant diameter.

The correct position has been reached when the implant length laser marking of 8-11-15 or 6-9-13 respectively is flush with the top margin of the guide sleeve in the SAFE Guide.

The max speed for the punch is 800 rpm.

## Initial Drill EV-GS

For minimally invasive treatments, the use of the Initial Drill EV-GS is essential to remove the mucosa and, if necessary, the bone to the planned implant shoulder. The Initial Drill is guided directly by the guide sleeve.

The correct position has been reached when the implant length laser marking of 8-11-15 or 6-9-13 respectively is flush with the top margin of the guide sleeve.

## ①-Drill EV-GS 1.9

The ①-Drill, with the corresponding ①-Sleeve attached, is placed in the guide sleeve. Start drilling and prepare the osteotomy until the physical depth stop is reached. While rotating, pull out the drill and then stop before removing the drill with the attached drill sleeve out of the guide sleeve.

(See page 14 for more details.)

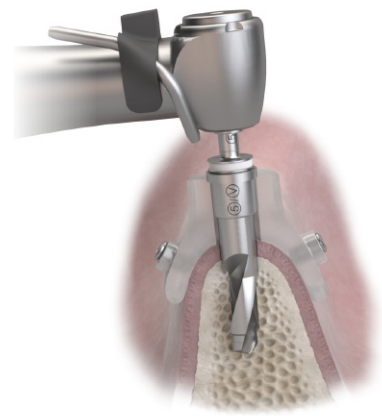
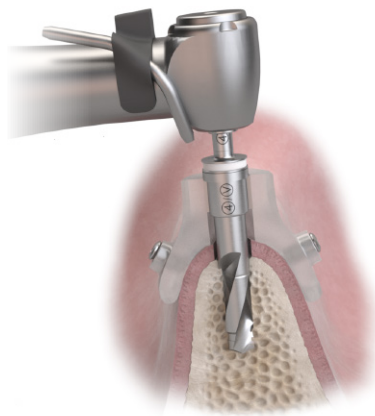
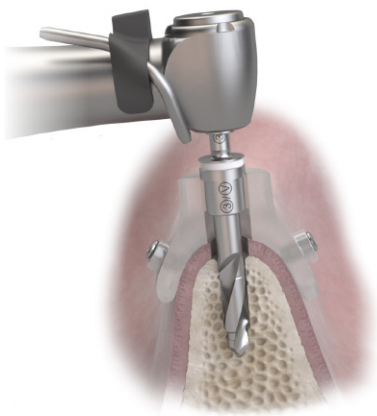

③-Drill EV-GS 2.5/3.1

Use the ③-Drill with the corresponding ③/∅-Sleeve for the last drilling step to prepare the osteotomy for a 3.6 Straight or 4.2 Conical / Profile Conical Implant.

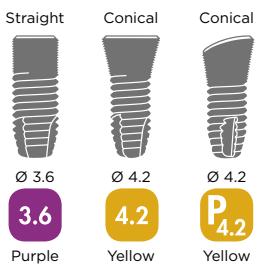

④-Drill EV-GS 3.1/3.7

Use the ④-Drill with the corresponding ④/∅-Sleeve for the last drilling step to prepare the osteotomy for a 4.2 Straight / Profile Straight or 4.8 Conical / Profile Conical Implant.

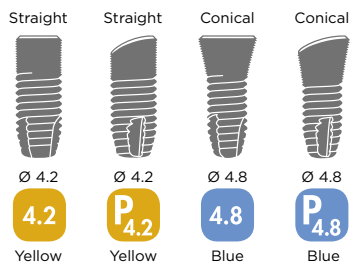

⑤-Drill EV-GS 3.7/4.3

Use the ⑤-Drill with the corresponding ⑤/∅-Sleeve for the last drilling step to prepare the osteotomy for a 4.8 Straight / Profile Straight Implant.

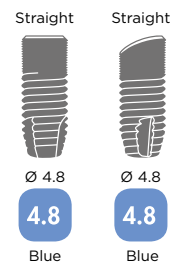



## Preparation for Straight Implants

For all straight implants, use one of the cortical A or B Drills for the final cortical bone preparation.

## Preparation for Conical Implants

For all conical implants, use one of the conical A/B-Drills for the final cortical bone preparation.

## Additional osteotomy preparation

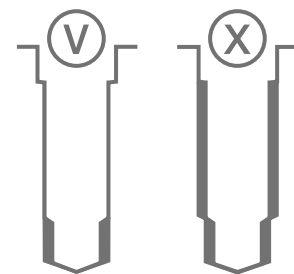
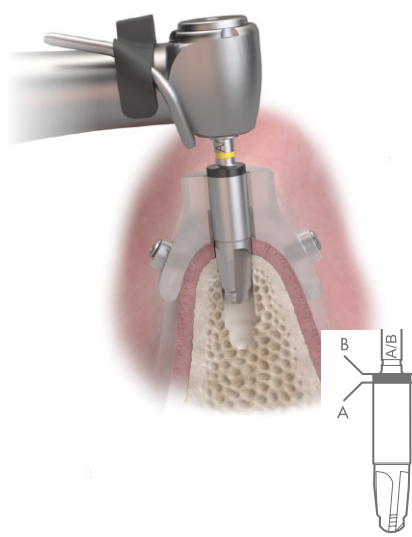
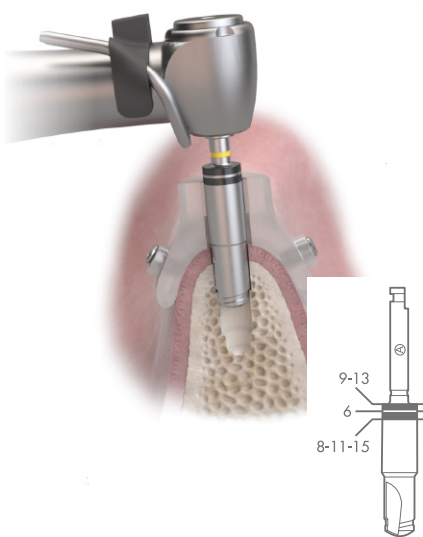

### Ⓐ-Drill EV-GS Ⓑ-Drill EV-GS Cortical bone preparation - straight implants

Mandatory preparation of the cortical layer to reduce pressure in the bone around the implant neck.

Choose the specific cortical drill based on the cortical bone thickness:

Cortical Drill Ⓐ  for a thin < 2mm cortical bone

Cortical Drill Ⓑ  for a thick ≥ 2mm cortical bone

Finalize the osteotomy by drilling to the full depth indicated by the marked line. The Ⓐ and Ⓑ Drills are directly guided. The correct position has been reached when the implant length laser marking of 8-11-15 mm, 9-13 mm or the 6 mm respectively is flush with the top margin of the guide sleeve.

**Note:** There is a separate laser mark position for the 6mm implant.

### Ⓐ/Ⓑ-Drill EV-GS Cortical bone preparation - conical implants

Mandatory preparation of the cortical layer to reduce pressure in the bone around the implant neck.

Use the Ⓐ/Ⓑ Conical Drill according to the Implant Diameter 4.2 and 4.8 for all Conical and Profile EV Conical Implants with the length of 9-13 or 8-11-15.

Depth markings are based on the cortical bone thickness:

Ⓐ for thin < 2mm cortex, drill to the apical border of the depth indication line.

Ⓑ in thick ≥ 2mm cortex, drill to the full depth.

The Drill shaft has to be flush with the top margin of the guide sleeve.

### Additional spongy bone preparation

When deemed necessary, the preparation can be performed with either of the following drills:

#### Ⓥ-Drill EV-GS - extra apical preparation

Following the opening of the marginal cortical layer with Ⓐ or Ⓑ Cortical Drill or Ⓐ/Ⓑ Conical Drill, the Ⓥ Drill is used to relieve the apical bone support.

#### ⓧ-Drill EV-GS - extra body preparation

Following the opening of the marginal cortical layer with Ⓑ Cortical Drill or Ⓐ/Ⓑ Conical Drill, the ⓧ Drill may be used. In addition to relieving the apical bone support, it widens the body portion of the osteotomy in situations with more dense bone, e.g. the lower jaw.

**Note:** For conical implants, this color refers to the implant body diameter.

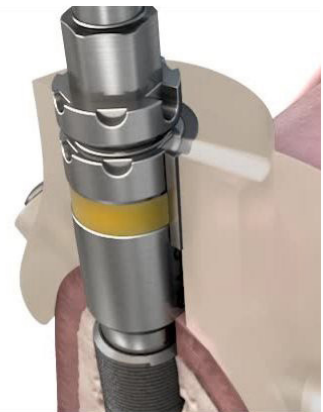
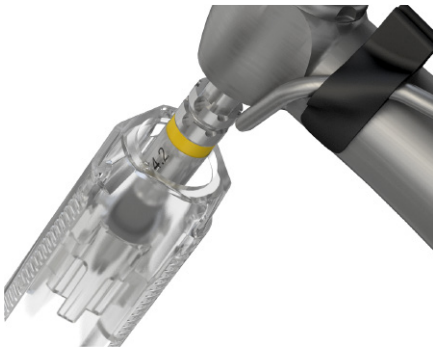

### Implant pick up

Attach the appropriate Implant Driver EV-GS to the contra angle.

- Ensure that the implant driver is fully seated into the implant.
- Press downwards to activate the carrying function before picking up the implant.
- When picking up the implant from the inner container, do not use excessive pressure.

**Note:** The Implant Driver EV-GS is seated in one-position-only.

It is recommended to have a titanium forceps available in case the implant driver does not provide sufficient carrying function during the removal procedure.

### Implant installation - machine

Install the implant with the contra angle at low speed (25 rpm) and set the maximum torque to 45 Ncm. Use profuse irrigation.

The grooves indicate the implant length. The lower one is for lengths 8-11-15 mm, the upper is for 6-9-13 mm.

The correct groove has to be flush with the guide sleeve.

### Implant installation with the Torque Wrench EV

For manual seating of the implant, attach the appropriate Implant Driver EV-GS by pressing it firmly into the Surgical Driver Handle EV. The driver is correctly seated when the color-coded marking is just in contact with the handle.

- Ensure that the implant driver is fully seated into the implant.
- Press downwards to activate the carrying function before picking up the implant.

**Note:** The Implant Driver EV-GS is seated in one-position-only.

Install the implant with the torque wrench at maximum 45 Ncm.

Use profuse irrigation.

### Implant installation for prefabricated stock abutments:

One of the six notches on the driver shaft has to be aligned with the notch in the guide sleeve of the Simplant SAFE Guide.

### Implant installation for pre-surgically fabricated Atlantis Abutments and Profile EV:

The single long notch on the implant driver shaft (on both Straight/Conical and Profile, see p 13) indicates the one-position-only, which must be aligned with the notch in the guide sleeve of the Simplant SAFE Guide.

**Note:** Do not exceed 45 Ncm when installing the implant. If the implant is not completely seated before reaching 45 Ncm, reverse/remove the implant and widen the osteotomy appropriately (see the alternatives for additional preparation of the osteotomy).

It is recommended to have a titanium forceps available in case the implant driver does not provide sufficient carrying function during the removal procedure.

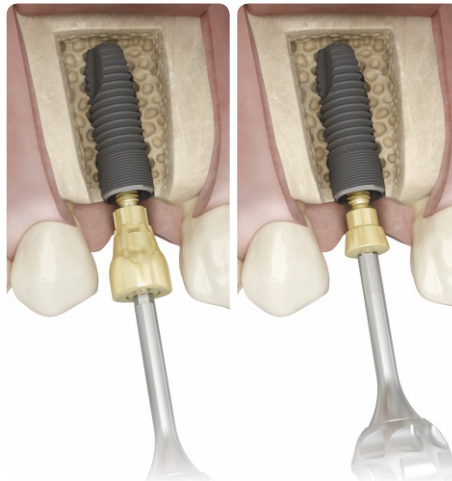
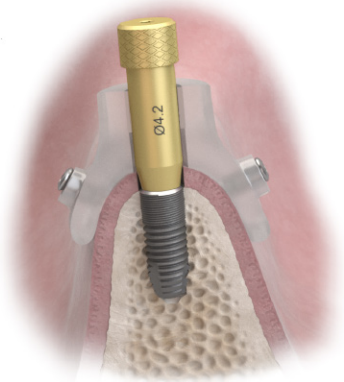

### EV-Stabilization Abutment

For multiple implant cases, you can use the stabilization abutment to secure the guide against lateral and horizontal movements and twisting. For easier removal, the stabilization abutment should be hand-tightened using a Hex Driver EV.

### Finalizing implant installation

Finalize the procedure of the implant installation according to a one- or two-stage approach by attaching a suitable healing abutment EV or a cover screw EV.

For details, see Astra Tech Implant System EV Surgical Manual.

## Step-by-step: Immediate temporary restoration directly following the implant placement

For mucosa- and tooth-supported cases – with the EV-PositioningAid or EV-Positioning Aid Profile, a plaster cast is necessary for the fabrication of the prosthetic restoration.

When using Simplant, an immediate restoration can be prepared before surgery based on the planning data.

### Application of the EV - PositioningAid

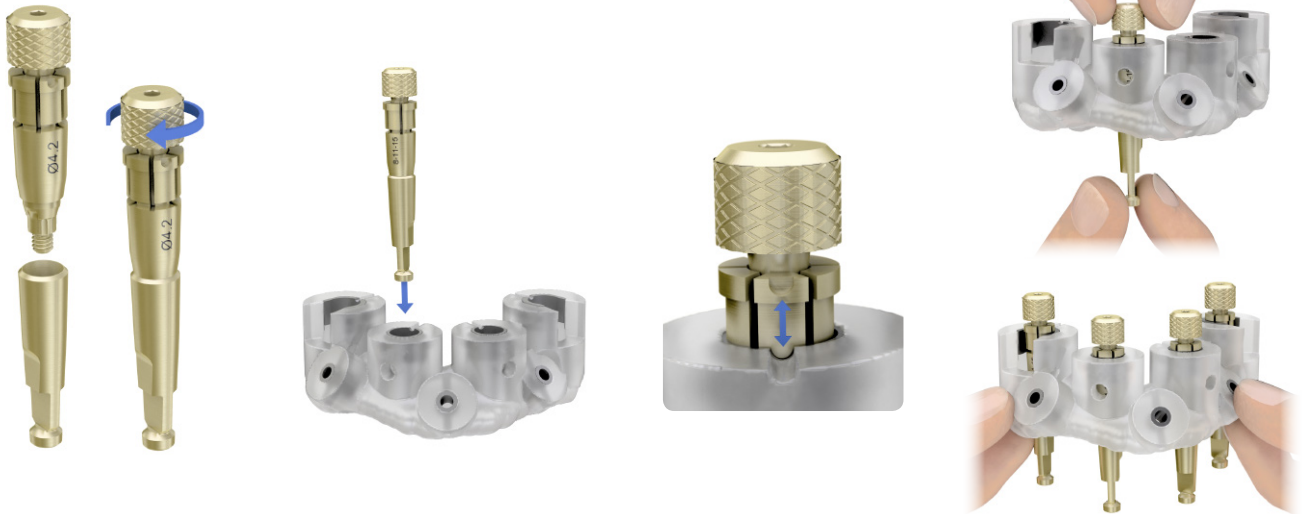

1. Screw the EV-PositioningAid loosely into the implant replica to avoid premature expansion.

**Note:** Before using the PositioningAid, check for possible damage on the outside. If signs of wear are visible, replace it with a new one.

2. Insert the joined components into the respective sleeve of the guide. The EV-PositioningAid must be seated in the guide completely up to the stop collar. Do not mount the retaining screw too tightly into the PositioningAid, as this will expand it and it will no longer be possible to correctly position it in the guide sleeve. In case of high expansion, loosen the screw and lift it.

3. The single notch of the EV-PositioningAid must be aligned with the notch in the guide sleeve. The alignment of the notches ensures the transfer of the planned implant position to the master cast.

4. Tighten the screw firmly by hand. Thereby the EV-PositioningAid is expanded and securely fixed in position in the guide.

**Preparation:**

Position the Simplant SAFE Guide on the plaster cast, check for an exact fit and, if necessary, remove imperfections, etc. on the cast. Once the Simplant SAFE Guide is seated precisely on the cast, fabricate a silicone key over the guide and plaster cast section in the region of the implants. Then mark the designated position of

the implant replicas on the plaster cast through the guide sleeves using a pencil. Using a plaster milling tool, remove the plaster at the pencil markings such that there is sufficient space for the implant replicas.

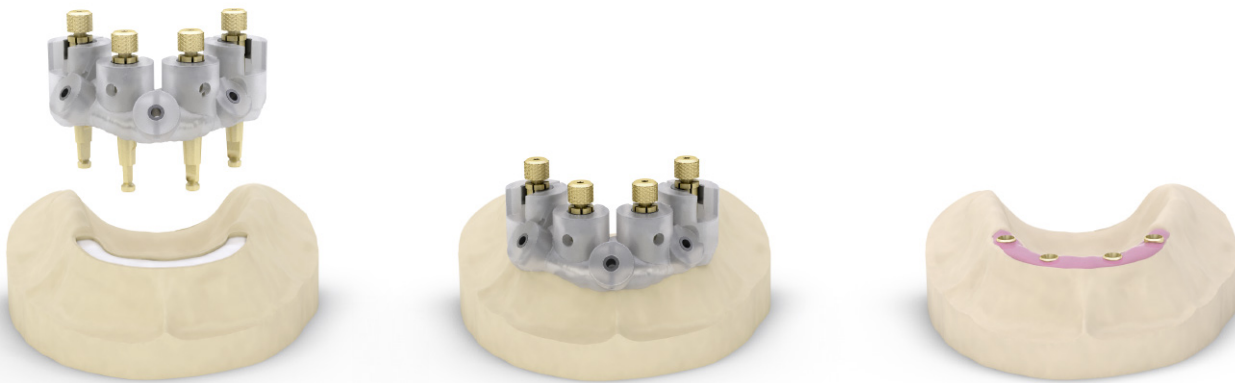

**5.** Again place the Simplant SAFE Guide on the plaster cast with the EV-PositioningAid and the connected implant replicas in place. Then check that there is no contact between the components and the cast. If necessary, adjust the plaster cast in order to guarantee a tension-free fit.

**6.** Block any possible gaps between the EV-PositioningAid and the guide sleeves with wax or similar to prevent leakage of the plaster. The technique with a gingival mask around the shoulder of the replicas is recommended. The initially fabricated silicone key may be used to reproduce the previous model form and mucosal contouring. Then fill the space, initially created in the cast with plaster, in order to fix the implant replicas firmly.

**7.** Carefully unscrew each EV-PositioningAid by using the Hex Driver EV after the plaster has set and remove the guide. A master cast has now been created which can be used to produce an immediate temporary restoration.

# Guided surgery with Astra Tech Implant System® EV - Design features



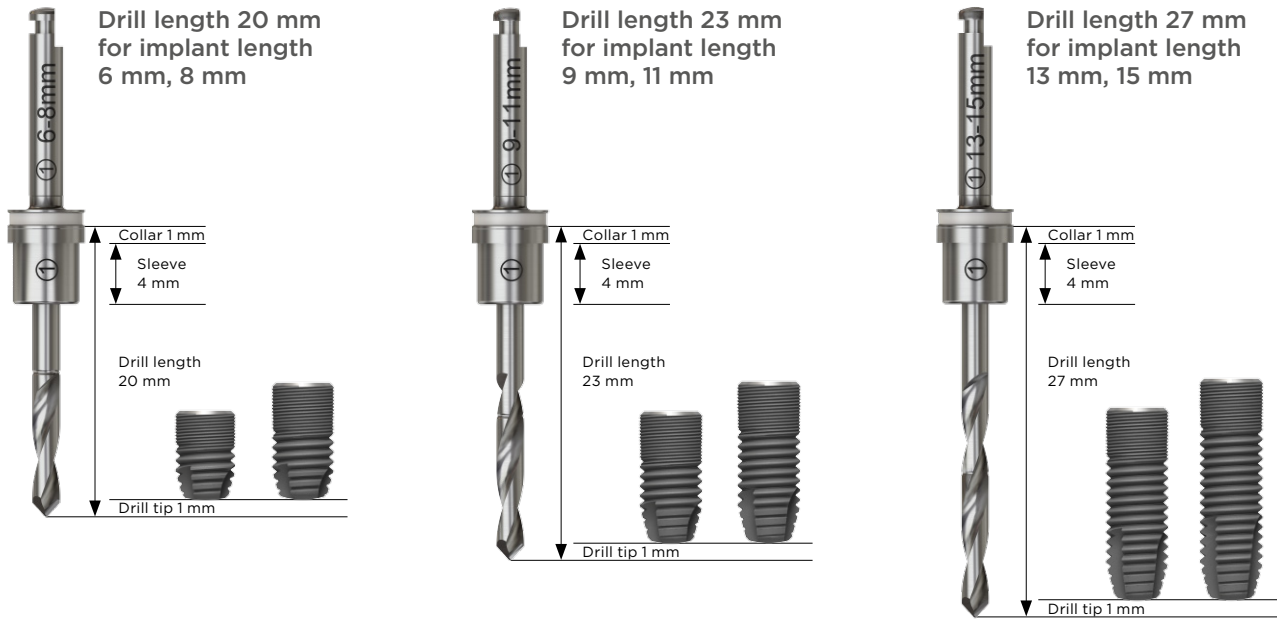





## Measurement principles



## Drill length with the corresponding implant length

Implant length	+ Prolongation	+ Drill tip	+ Sleeve	+ Sleeve collar	= Drill length
6 mm	8 mm	1 mm	4 mm	1 mm	20 mm
8 mm	6 mm	1 mm	4 mm	1 mm	20 mm
9 mm	8 mm	1 mm	4 mm	1 mm	23 mm
11 mm	6 mm	1 mm	4 mm	1 mm	23 mm
13 mm	8 mm	1 mm	4 mm	1 mm	27 mm
15 mm	6 mm	1 mm	4 mm	1 mm	27 mm

### Drill length with the corresponding implant length

Implant length		Drill length
 <p>6 mm</p>	 <p>8 mm</p>	 <p>20 mm</p>
 <p>9 mm</p>	 <p>11 mm</p>	 <p>23 mm</p>
 <p>13 mm</p>	 <p>15 mm</p>	 <p>27 mm</p>

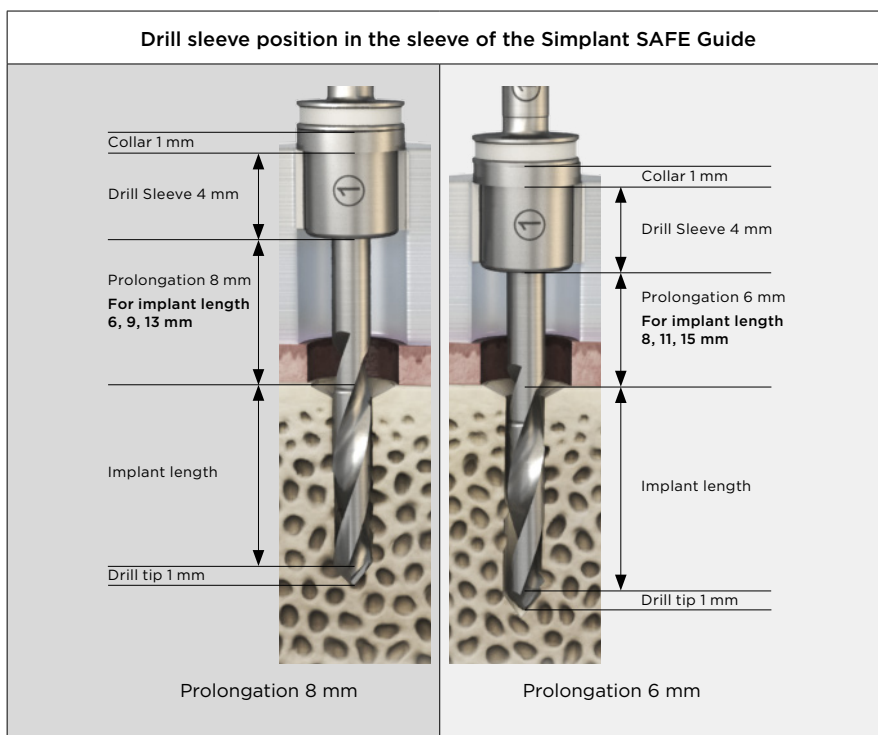

EV Guided Surgery based on Simplant 3D planning software and Simplant SAFE Guide uses drill sleeves on drills for guiding. These drill sleeves (ND and WD) have outer diameters adapted to the inner dimensions of the titanium guide sleeves in the SAFE Guide. The guide sleeves have an inner diameter of 4.6 mm (ND) / 5.2 mm (WD) and a length of 4 mm.

The drill sleeves are in turn guided by the sleeves in the Simplant SAFE Guide. The position of this guide sleeve is decided by Simplant and cannot be changed.

**Caution:** When using Astra Tech Implant System EV Guided Surgery instruments with products of alternative manufacturers of 3D planning software and/or guides, the manufacturer's instructions for the specifically defined guiding accessories (e.g. guide sleeve) must be followed.

# Product catalog

Computer-guided implant treatment  
with the Astra Tech Implant System® EV



# One surgical Tray – two overlay options

## One surgical tray – two overlay options

The guided surgical tray design with two interchangeable overlays allows for adaptation of tray content according to your clinical preferences.

### Streamline

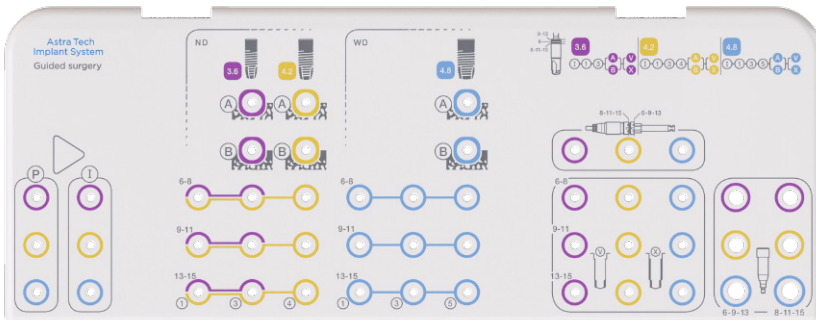

### Streamline

The Streamline Overlay supports the OsseoSpeed EV straight implants (3.6, 4.2, 4.8) from 6 mm to 15 mm.

### Proline

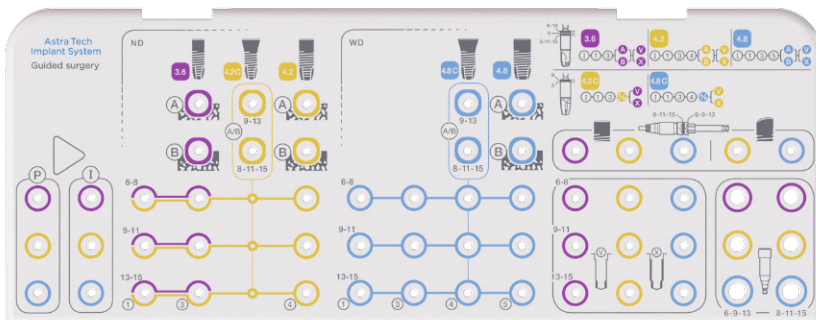

### Proline

The Proline Overlay supports the complete assortment within guided surgery of OsseoSpeed EV implants (3.6, 4.2, 4.8) including straight (6–15 mm), conical (8–15 mm) and Profile EV (8–15 mm).

The overlays can be snapped onto the tray base. This solution offers the possibility of adapting the tray's contents according to individual preferences.

	Large Tray EV (without overlay)	Streamline	Proline
Order No.	25769	26099	26098

### OsseoSpeed® EV

	Straight			Conical		Profile Straight		Profile Conical	
Ø	3.6 S	4.2 S	4.8 S	4.2 C	4.8 C	P 4.2 PS	P 4.8 PS	P 4.2 PC	P 4.8 PC
Length									
6 mm	+	+	+						
8 mm	+	+	+	+	+	+	+	+	+
9 mm	+	+	+	+	+	+	+	+	+
11 mm	+	+	+	+	+	+	+	+	+
13 mm	+	+	+	+	+	+	+	+	+
15 mm	+	+	+	+	+	+	+	+	+

# Punch/Initial Drill

## Punch EV-GS

Stainless steel

- Intended for gingivectomy by flapless surgery
- Laser depth indicator according to implant length
- Delivered sterile
- Laser marked with (P), single use (X) and corresponding implant diameter
- Color: corresponds to the implant
- Single-use

**Note:** By using Simplant software or mySimplant planning service, these punches can be ordered case-specific with the SAFE Guide.

## Punch EV-GS



Ø mm	3.6	4.2	4.8
Order No.	26010	26011	26012

## Initial Drill

Stainless steel

- Creating a starting point for the following drills
- Laser depth indicator according to implant length
- Delivered sterile
- Laser marked with (I) and corresponding implant diameter
- Color: corresponds to the implant
- Multiple-use

## Initial Drill



Ø mm	3.6	4.2	4.8
Order No.	26013	26014	26015

# Spongy bone preparation

## Drill EV-GS with narrow diameter Sleeve (ND)

1-Drill EV-GS, ND



3.6 4.2

3-Drill EV-GS, ND



3.6 4.2

4-Drill EV-GS, ND



4.2

Ø mm	Ø1.9 ND	Ø2.5/3.1 ND	Ø3.1/3.7 ND
Implant length	6–8 mm	6–8 mm	6–8 mm
Order No.	26051	26054	26057
Implant length	9–11 mm	9–11 mm	9–11 mm
Order No.	26052	26055	26058
Implant length	13–15 mm	13–15 mm	13–15 mm
Order No.	26053	26056	26059

## Drill EV-GS with narrow diameter Sleeve (ND)

Stainless steel

- Drills for spongy bone preparation
- Physical depth stop
- Delivered sterile with a drill sleeve
- Laser marked with the corresponding number and drill diameter
- Color: white for all drill diameters
- Drill: Multiple-use
- Sleeve: Single-use

**Note:** By using Simplant software or mySimplant planning service, these Drills can be ordered case-specific with the SAFE Guide.

## Drill EV-GS with wide diameter Sleeve (WD)

1-Drill EV-GS, WD



4.8

3-Drill EV-GS, WD



4.8

4-Drill EV-GS, WD



4.8

5-Drill EV-GS, WD



4.8

Ø mm	Ø1.9 WD	Ø2.5/3.1 WD	Ø3.1/3.7 WD	Ø3.7/4.3 WD
Implant length	6–8 mm	6–8 mm	6–8 mm	6–8 mm
Order No.	26060	26063	26066	26069
Implant length	9–11 mm	9–11 mm	9–11 mm	9–11 mm
Order No.	26061	26064	26067	26070
Implant length	13–15 mm	13–15 mm	13–15 mm	13–15 mm
Order No.	26062	26065	26068	26071

## Drill EV-GS with wide diameter Sleeve (WD)

Stainless steel

- Drills for spongy bone preparation
- Physical depth stop
- Delivered sterile with a drill sleeve
- Laser marked with the corresponding number and drill diameter
- Color: white for all drill diameters
- Drill: Multiple-use
- Sleeve: Single-use

**Note:** By using Simplant software or mySimplant planning service, these Drills can be ordered case-specific with the SAFE Guide.

## Cortical bone preparation – straight implants

### Cortical Drill EV-GS

Stainless steel

- For straight implants
- Drills for the mandatory preparation of the cortical layer to reduce pressure in the bone around the implant neck
- Delivered sterile
- Color: corresponds to implant
- Laser marked with (A) or (B), the drill diameter and implant length
- Laser etched depth indicator
- (A) – thin cortical bone < 2 mm
- (B) – thick cortical bone ≥ 2 mm
- Multiple-use

### Cortical Drill EV-GS

(A)-Cortical Drill EV-GS (B)-Cortical Drill EV-GS (A)-Cortical Drill EV-GS (B)-Cortical Drill EV-GS (A)-Cortical Drill EV-GS (B)-Cortical Drill EV-GS



Ø mm	Ø3.1/3.3	Ø3.1/3.6	Ø3.7/3.9	Ø3.7/4.2	Ø4.3/4.5	Ø4.3/4.8
Order No.	26004	26005	26006	26007	26008	26009

## Cortical bone preparation – conical implants

### Conical Drill EV-GS

Stainless steel

- For conical implants
- Drills for the mandatory preparation of the cortical layer to reduce pressure in the bone around the implant neck and to prepare the conical part of the cavity
- (A) – thin cortical bone < 2 mm
- (B) – thick cortical bone ≥ 2 mm
- Delivered sterile
- Color: corresponds to implant
- Laser marked with (A/B), the drill diameter and implant length.
- Multiple-use

### Conical Drill EV-GS

A/B-Drill EV-GS 4.2C, 9-13 A/B-Drill EV-GS 4.2C, 8-11-15 A/B-Drill EV-GS 4.8C, 9-13 A/B-Drill EV-GS 4.8C, 8-11-15



Ø mm	Ø3.1/4.2	Ø3.1/4.2	Ø3.7/4.8	Ø3.7/4.8
Order No.	26000	26001	26002	26003

# Alternative spongy bone preparation

## V-Drill EV-GS

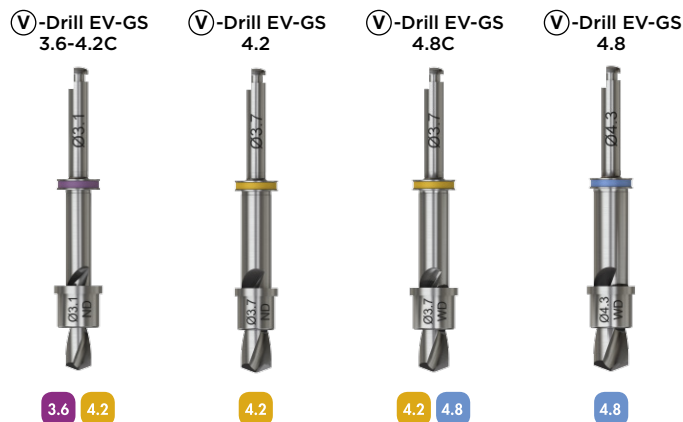

Ø mm	Ø3.1	Ø3.7	Ø3.7	Ø4.3
Implant length	6–8 mm	6–8 mm	6–8 mm	6–8 mm
Order No.	26084	26087	26090	26093
Implant length	9–11 mm	9–11 mm	9–11 mm	9–11 mm
Order No.	26085	26088	26091	26094
Implant length	13–15 mm	13–15 mm	13–15 mm	13–15 mm
Order No.	26086	26089	26092	26095

## X-Drill EV-GS

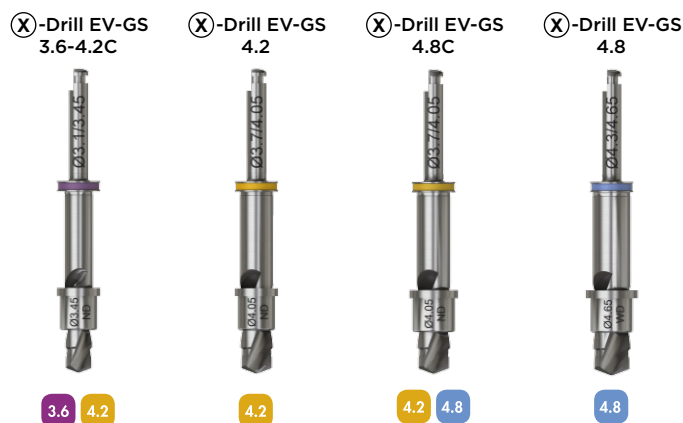

Ø mm	Ø3.1/3.45	Ø3.7/4.05	Ø3.7/4.05	Ø4.3/4.65
Implant length	6–8 mm	6–8 mm	6–8 mm	6–8 mm
Order No.	26072	26075	26078	26081
Implant length	9–11 mm	9–11 mm	9–11 mm	9–11 mm
Order No.	26073	26076	26079	26082
Implant length	13–15 mm	13–15 mm	13–15 mm	13–15 mm
Order No.	26074	26077	26080	26083

## Alternative spongy bone preparation

### V-Twist Drill – extra apical preparation

Following opening of the marginal cortical layer with cortical drill (A), (B) or conical drill (A<sub>b</sub>), the (V) drill is used to relieve the apical bone support when this support is not indicated.

- Use to widen the apical portion of the osteotomy
- Physical depth stop
- Delivered sterile with Sleeve on Drill
- Laser marked with (V), the drill diameter and implant length
- Color: corresponds to implant **Note:** for conical implants, this color refers to the implant body diameter.
- Drill: Multiple-use
- Sleeve: Single-use

**Note:** By using Simplant software or mySimplant planning service, these Drills can be ordered case-specific with the SAFE Guide.

### X-Step Drill – extra body preparation

Following opening of the marginal cortical layer with cortical drill (B) or conical drill (A<sub>b</sub>), the (X) drill, in addition to relieving the apical bone support, is used to widen the body portion of the osteotomy in situations with more dense bone, e.g. the lower jaw.

- Physical depth stop
- Delivered sterile with Sleeve on Drill
- Laser marked with (X), the drill diameter and implant length
- Color: corresponds to implant **Note:** for conical implants, this color refers to the implant body diameter.
- Drill: Multiple-use
- Sleeve: Single-use

**Note:** By using Simplant software or mySimplant planning service, these Drills can be ordered case-specific with the SAFE Guide.

# Implant Driver EV-GS

## Surgical Instruments Implant Driver EV-GS

Stainless steel, non-sterile

- For picking up and installing implant
- With two level grooves to indicate the depth position according to the guide
- Six notches for Straight and Conical to facilitate the correct position
- One notch for OsseoSpeed Profile EV to facilitate the correct position

**Note:** For use with Contra Angle or Torque Wrench EV Surgical Driver Handle order No. 25775

Astra Tech Implant System EV Product Catalog

- The Extender EV-GS can be used for drills and implant drivers

## Implant Driver EV-GS

Implant Driver EV-GS 3.6



3.6

Implant Driver EV-GS 4.2



4.2

Implant Driver EV-GS 4.8



4.8

Implant Driver Extender EV-GS



Version	Straight and Conical	Straight and Conical	Straight and Conical	
Order No.	26016	26017	26018	26021
		<b>P</b> <sub>4.2</sub>	<b>P</b> <sub>4.8</sub>	
Version		Profile	Profile	
Order No.		26019	26020	

# PositioningAid

## Positioning System

Titanium

- Multiple-use
- Color: corresponds to implant
- Laser markings: Implant length 6-9-13 mm or 8-11-15 mm

## Positioning System

EV-PositioningAid



3.6

EV-PositioningAid



4.2

EV-PositioningAid

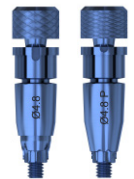

4.8

Ø mm	Ø3.6	Ø4.2	Ø4.8
Implant length	8-11-15 mm	8-11-15 mm	8-11-15 mm
Type	Straight and Conical	Straight and Conical	Straight and Conical
Order No.	26039	26041	26043
Implant length	6-9-13 mm	6-9-13 mm	6-9-13 mm
Type	Straight and Conical	Straight and Conical	Straight and Conical
Order No.	26040	26042	26044
		<b>P</b> <sub>4.2</sub>	<b>P</b> <sub>4.8</sub>
Implant length		8-11-15 mm	8-11-15 mm
Type		Profile	Profile
Order No.		26045	26047
Implant length		6-9-13 mm	6-9-13 mm
Type		Profile	Profile
Order No.		26046	26048

# Fixation System

## Stabilization Abutments

### EV-Stabilization Abutment



3.6

### EV-Stabilization Abutment



4.2

### EV-Stabilization Abutment



4.8

## Stabilization Abutments

Titanium

- Multiple-use
- Color: corresponds to the implant
- Stabilizes the guide for further implant treatment
- Laser markings: Implant length 6-9-13 mm or 8-11-15 mm and diameter

Ø mm	Ø3.6	Ø4.2	Ø4.8
Implant length	8-11-15 mm	8-11-15 mm	8-11-15 mm
Order No.	26033	26035	26037
Implant length	6-9-13 mm	6-9-13 mm	6-9-13 mm
Order No.	26034	26036	26038

## Fixation System

### Drill for Guide Fixation Screw



14 mm

### Guide Fixation Screw



Ø2.0

Order No.	26050	26049
-----------	-------	-------

## Fixation System

Stainless steel

- Delivered sterile
- Drill: Multiple-use
- Prepare the bone for the fixation screw
- Screw: Single-use
- Secures the guide directly to the bone to avoid guide movement
- Hex on the top to fit the Hex Driver EV manual with ref. No. 25771, 25772, 25773

# Sleeves

## Sleeve-on-Drill™

### ND



3.6 4.2 4.2

3.65 4.25 4.2C

### WD



4.8 4.8

4.85 4.8C

Drill Type & Ø Inner	1-Sleeve Ø1.9 ND	1-Sleeve Ø1.9 WD
Order No.	26022	26027
Drill Type & Ø Inner	3/V-Sleeve Ø3.1 ND	3-Sleeve Ø3.1 WD
Order No.	26023	26028
Drill Type & Ø Inner	4/V-Sleeve Ø3.7 ND	4/V-Sleeve Ø3.7 WD
Order No.	26024	26029
Drill Type & Ø Inner	X-Sleeve Ø3.45 ND	5/V-Sleeve Ø4.3 WD
Order No.	26025	26030
Drill Type & Ø Inner	X-Sleeve Ø4.05 ND	X-Sleeve Ø4.05 WD
Order No.	26026	26031
Drill Type & Ø Inner	-	X-Sleeve Ø4.65 WD
Order No.	-	26032

## Sleeve-on-Drill™

Stainless steel

- Delivered sterile
- Laser marked with inner and outer sleeve diameter according to the corresponding drill type
- Outer sleeve diameter = inner guide sleeve size in the SAFE Guide  
ND = narrow diameter  
WD = wide diameter
- Single-use

**Note:** By using Simplant software or mySimplant planning service, these Sleeves can be ordered case-specific with the SAFE Guide.

## About Dentsply Sirona Implants

Dentsply Sirona Implants offers comprehensive solutions for all phases of implant therapy, including Ankylos®, Astra Tech Implant System® and Xive® implant lines, digital technologies, such as Atlantis® patient-specific solutions and Simplant® guided surgery, Symbios® regenerative solutions, and professional and business development programs, such as STEPPS™. Dentsply Sirona Implants creates value for dental professionals and allows for predictable and lasting implant treatment outcomes, resulting in enhanced quality of life for patients.

## About Dentsply Sirona

Dentsply Sirona is the world's largest manufacturer of professional dental products and technologies, with a 130-year history of innovation and service to the dental industry and patients worldwide. Dentsply Sirona develops, manufactures, and markets a comprehensive solutions offering including dental and oral health products as well as other consumable medical devices under a strong portfolio of world class brands. As The Dental Solutions Company™, Dentsply Sirona's products provide innovative, high-quality and effective solutions to advance patient care and deliver better, safer and faster dentistry. Dentsply Sirona's global headquarters is located in York, Pennsylvania, and the international headquarters is based in Salzburg, Austria. The company's shares are listed in the United States on NASDAQ under the symbol XRAY.

Visit [www.dentsplysirona.com](http://www.dentsplysirona.com) for more information about Dentsply Sirona and its products.